

1		
Description	Material	Finish
Body	Brass	Nickel
Pin	Brass	Gold
Insulation	Teflon	Teflon

BOTTOM VIEW

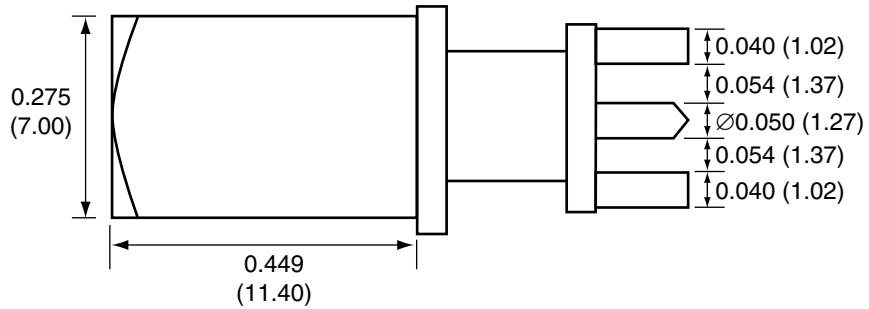

BACK VIEW

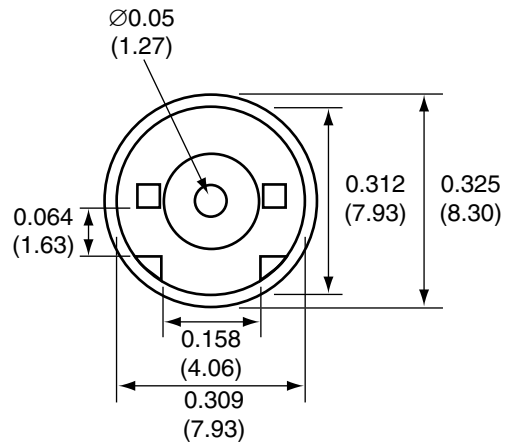

MOUNTING METHODS

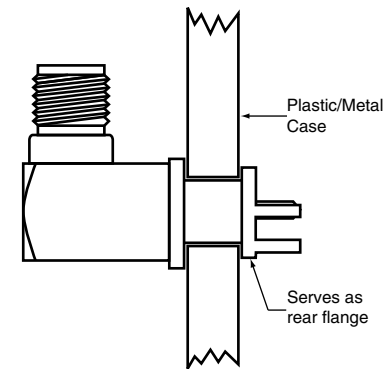

SIDE VIEW

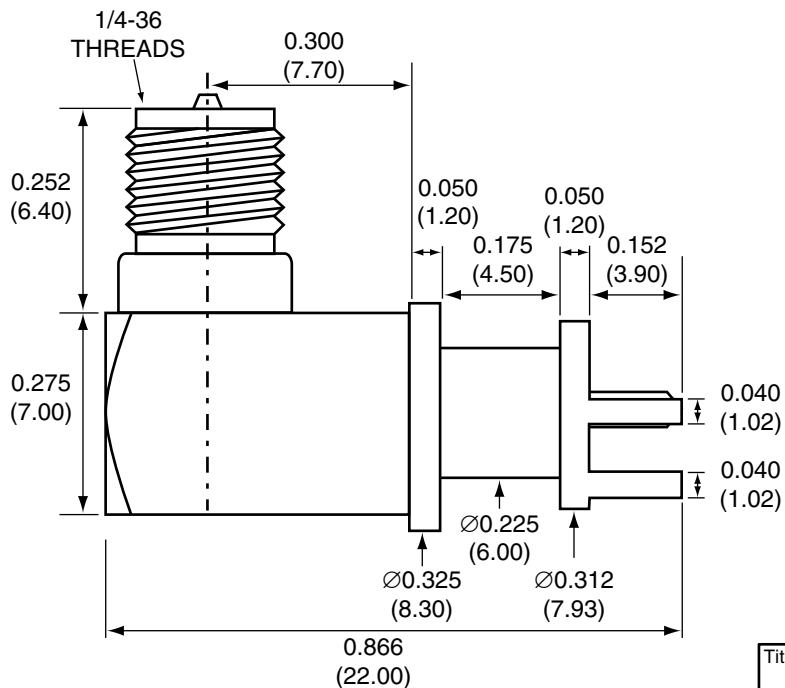

FRONT VIEW

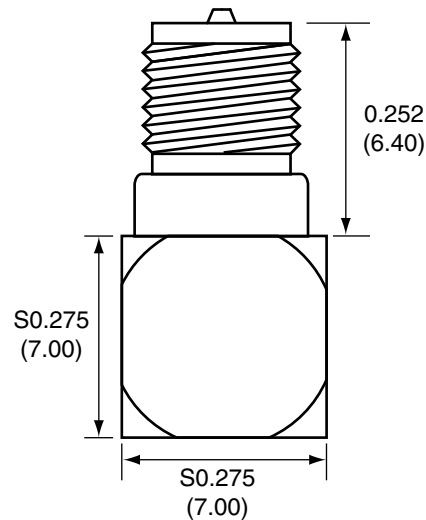

RECOMMENDED FOOTPRINT

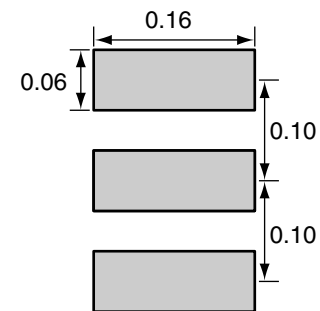

Title RP-SMA FEMALE RIGHT ANGLE EDGE
MULTI-MOUNT FOR 0.062" THICK BOARD

Part No. CONREV SMA009

Revision: 1.0

Dimensions: INCHES (mm)

Date: 3/2/2005

CONNECTOR CITY
159 ORT LANE
MERLIN, OR 97532
PH (541)-471-6256
FAX (541)-471-6251

Sheet 1 of 1

CONNECTOR CITY
THE VALUE OF CONNECTIONS